

# MS2610

Mariner Kit for use with HP EliteDesk 800 G6 Tower PC (Desktop configuration)



The HP EliteDesk 800 G6 Tower (TWR) PC is marine type approved by most of the major international marine Classification Societies when it is installed in conjunction with our Mariner Kit MS2610.

The MS2610 Mariner Kit is designed to fit onto any horizontal surface and affords protection against the effects of vibration and shock experienced in the offshore marine environment and has been tested against IACS Unified Requirement E10 and the relevant sections of IEC60945 (see below right for test details).

This type approved combination of hardware and Mariner Kit can be used as the platform for your critical navigation, control, loading and general purpose applications (please check individual type approval certificates for any restrictions).

## PRODUCT FEATURES

- ◆ The redesigned HP EliteDesk 800 G6 Tower is the new definition of performance and expandability in a business-class tower PC
- ◆ Featuring powerful components, enormous expansion, and strong security, this PC handles your biggest enterprise workloads
- ◆ Intel® Q470 chipset supporting Intel® 10th generation Core™ processors, featuring integrated Intel® UHD Graphics and Intel® vPro™ Technology (available with Core i3, Core i5 and Core i7 processors)
- ◆ Five bays and four full-height slots including one slot for full-length double-wide graphics, plus three additional M.2 slots and 11 USB ports
- ◆ Two rear USB 2.0 USB ports; two front (including one fast charging) and two rear USB 3.2 Gen 1 ports; two front and two rear USB 3.2 Gen 2 ports; one front USB Type-C 3.2 Gen 2 port
- ◆ 1 x DisplayPort™ 1.4; 1 x RJ45 Network connector; 1 x RS-232 Serial port (optional)
- ◆ ENERGY STAR® certified and EPEAT® 2019 registered where applicable
- ◆ CCC, CECP and SEPA certified
- ◆ Compliant with the Restrictions of Hazardous Substances (RoHS) directive – 2011/65/EC
- ◆ Designed to comply with the Waste Electrical and Electronic Equipment (WEEE) directive – 2002/96/EC
- ◆ PC chassis and all internal components and modules are manufactured with low halogen content
- ◆ Three-year limited warranty on parts and labour as standard

This Mariner Systems solution is tested against the consolidated 'worst-case' requirements of all the following major international marine Classification Societies:

**ABS, BV, CCS, ClassNK, DNV, KR, LR, PRS, RINA**

Tests included within the test programme are as follows:

- > Vibration, Shock, Static and Dynamic Inclination
- > Dry & Damp Heat, Low Temperature
- > Acoustic Noise, Compass Safe Distance
- > High Voltage, Power Supply Variation & Power Supply Failure
- > Conducted LF & RF, Electromagnetic Field
- > Radiated & Conducted Emissions, Electrostatic Discharge
- > Insulation Resistance, Burst / Fast Transients
- > Surge Immunity, Access to Dangerous Voltages

**“Steer the right course with Mariner Systems”**



# MS2610

## Mariner Kit for use with HP EliteDesk 800 G6 Tower PC (Desktop configuration)

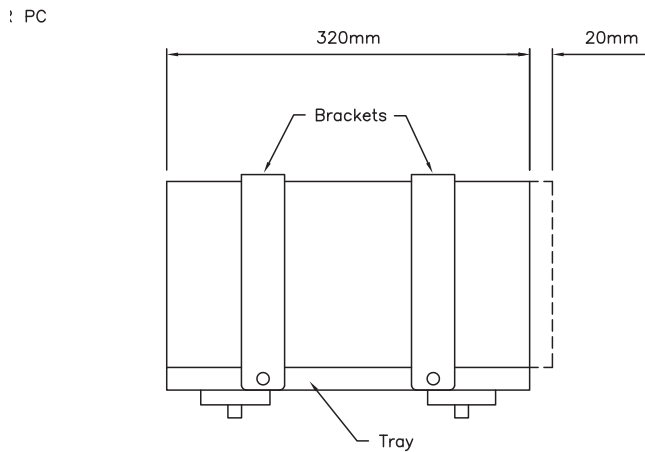
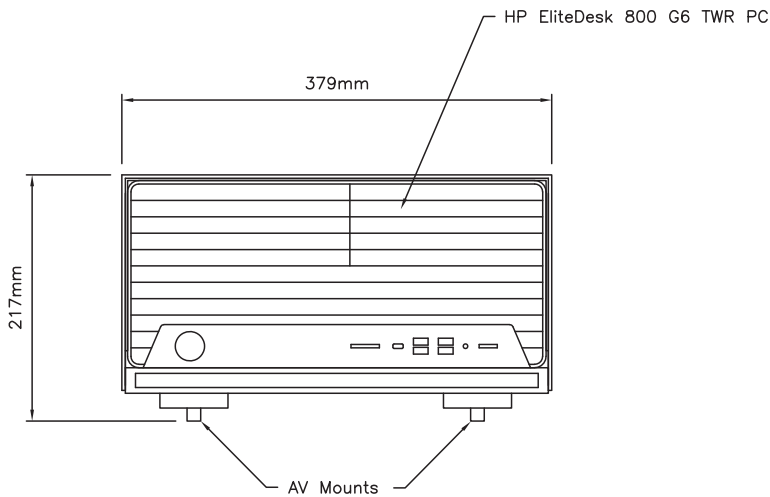

### Mariner Systems (UK) Limited

Oaklands Park • Wokingham • Berkshire • RG41 2FD • United Kingdom  
 Telephone: +44 (0) 118 979 6020 • Facsimile: +44 (0) 118 979 6021  
 sales@marinersystems.com • www.marinersystems.com

## OPERATING GUIDELINES

Although all of our solutions are tested against extreme environmental conditions for the purposes of marine type approval, installation should take into account the following guidelines:

- Keep the computer away from excessive moisture, direct sunlight and the extremes of heat and cold. Wherever possible, ensure that the unit is operated within the manufacturer's recommended operating range:

	Operating	Non-Operating
<b>Temperature</b>	+10° to +35°C (+50° to +95°F)	-30° to +65°C (-22° to +149°F)
<b>Humidity</b>	10% to 90% (non-condensing)	5% to 95% (non-condensing)

- Leave a 10.2 cm (4-inch) clearance on all vented sides of the computer to permit the required airflow
- Never restrict airflow into the computer by blocking any vents or air intakes
- Occasionally clean the air vents on all vented sides of the computer
- If the computer is to be operated within a separate enclosure, intake and exhaust ventilation must be provided on the enclosure, and the same operating guidelines listed above will still apply

By following these guidelines you will maximise the life of your computer and minimise service costs.

## STATISTICS

<b>Overall Fitted Dimensions</b>	379mm (w) x 217mm (h) x 340mm (d)
<b>Weight (Mariner Kit only)</b>	2.2 kg
<b>Weight (including hardware)</b>	12.1 kg (exact weight depends upon configuration)
<b>Chipset</b>	Intel® Q470
<b>Processor</b>	Intel® 10th Generation Core™ i7, i5 & i3; Intel® Pentium®
<b>Memory</b>	Up to 128 GB DDR4-2666 DIMM
<b>Storage</b>	500 GB to 2 TB 3.5-inch SATA (7,200 rpm); 500 GB to 1 TB 2.5-inch SATA (7,200 rpm); 500 GB 2.5-inch SATA SED Opal 2 (7,200 rpm); 256 GB to 512 GB M.2 2280 PCIe NVMe SSD; 256 GB to 2 TB M.2 2280 PCIe NVMe TLC SSD
<b>Keyboard</b>	HP USB Keyboard
<b>Mouse</b>	HP USB Mouse
<b>Networking (integrated)</b>	Intel® I219LM GbE LOM
<b>Graphics (integrated)</b>	Intel® UHD Graphics
<b>Optical Storage</b>	HP 9.5mm Slim DVD-ROM; HP 9.5mm Slim DVD Writer
<b>Operating System</b>	Windows 10; FreeDOS
<b>Expansion Slot</b>	2 x full-height PCI Express x1 (v3.0) slots; 2 x full-height PCI Express x16 (v3.0) slots (one wired as a x4)
<b>USB Support</b>	2 x USB 2.0 ports – rear; 4 x USB 3.2 Gen 1 ports – 2 front and 2 rear; 4 x USB 3.2 Gen 2 ports – 2 front and 2 rear; 1 x USB Type-C™ 3.1 Gen 2 – front
<b>Rear I/O</b>	1 x DisplayPort™ 1.4; 1 x RJ-45 Network connector; 1 x RS-232 Serial port (optional)
<b>Operating Voltage Range</b>	90 – 264 VAC